



Modular Cooking Range Line 900XP Gas Solid Top on Gas Oven with 2 Burners with 3mm worktop and electric ignition

ITEM # _____

MODEL # _____

NAME # _____

SIS # _____

AIA # _____



391257 (E9STGHT0G0)

Gas Solid Top (5,5 kW) with
2 Burners (1x10 kW, 1x6 kW)
on gas Oven (8,5 kW) with
3mm WorkTop and
electronic ignition

Short Form Specification

Item No. _____

High efficiency 5.5 kW central burner with flame failure device and electronic ignition. Large cooking surface with differentiated heating zones. Large flat cooking surface made in cast iron allows for the use of a number of various sized pots and pans, all easily moved across the surface without lifting. Oven chamber with 3 levels of runners to accommodate 2/1 GN shelves (2 steam pans). Ribbed, cast-iron oven base plate. High efficiency flower flame burners with continuous power regulation and optimized combustion. Flame failure device as standard on burners to protect against accidental extinguishing. Electronic ignition for burners. Exterior panels in stainless steel. 3mm worktop in 20/10, stainless steel. Right angled side edges eliminate gaps and possible dirt traps between units.

Main Features

- Gas heated, 5.5 kW central burner, solid top.
- Durable cast iron cooking plate, easy to clean.
- The center of the plate can reach a maximum temperature of 500 °C while decreasing outwards.
- Central burner with optimized combustion, flame failure device and protected pilot light.
- Piezo ignition.
- Temperature gradients to satisfy different cooking needs, provided over the whole plate thanks to the temperature fine-tuning by zone.
- Various sizes of pans can be used at the same time due to large surface area with no intermediate sectors.
- Pans can easily be moved from one area to another without lifting.
- Base compartment consists of a gas heated standard oven with stainless steel burners and self stabilizing flame positioned beneath the base plate. Oven chamber to have 3 levels of runners to accommodate 2/1 GN shelves (2 steam pans) and ribbed cast iron base plate.
- Oven thermostat adjustable from 120 °C to 280 °C.
- The 6 kW and one 10 kW high efficiency flower flame burners are available in two different sizes to suit high performing cooking requirements of the most demanding customers:
 - 60 mm burners with continuous power regulation from 1,5 to 6 kW
 - 100 mm burners with continuous power regulation from 2.2 kW to 10 kW
- Burners with optimized combustion.
- Flame failure device on each burner protects against gas leakage when accidental extinguishing of the flame occurs.
- Large sized pan support in cast iron (stainless steel as option) with long center fins to allow the use of the largest down to the smallest pans.
- All major compartments located in front of unit for ease of maintenance.
- The special design of the control knob system guarantees against water infiltration.

Construction

- Unit is 930 mm deep to give a larger working surface area.
- All exterior panels in Stainless Steel with Scotch Brite finishing.
- Model has right-angled side edges to allow flush fitting joints between units, eliminating gaps and possible dirt traps.
- Electric ignition.
- AISI 304 stainless steel worktop, 3mm thick.
- IPX5 water resistance certification.

Included Accessories

- 1 of GN2/1 chrome grid for static oven PNC 164250

APPROVAL: _____



Experience the Excellence
www.electroluxprofessional.com

Front

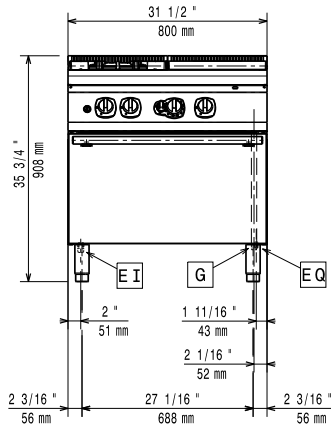

Side

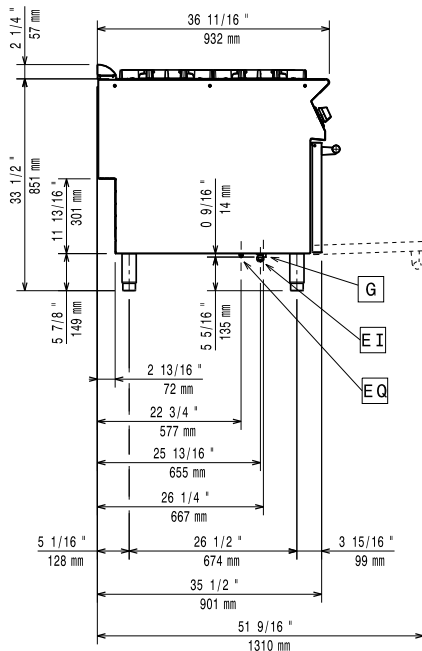

EI = Electrical inlet (power)
 EQ = Equipotential screw
 G = Gas connection

Top

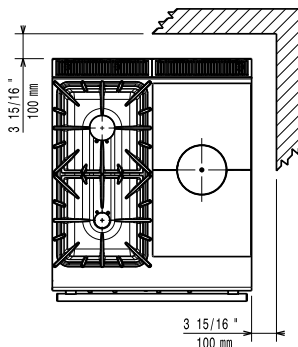
Gas

Gas Power:	
391257 (E9STGHT0G0)	30 kW
Standard gas delivery:	Natural Gas G20 (20mbar)
Gas Type Option:	LPG; Natural Gas; Town Gas
Gas Inlet:	1/2"

Key Information:

Front Burners Power:	6 - kW
Back Burners Power:	10 - 0 kW
Back Burners Dimension - mm	Ø 100
Front Burners Dimension - mm	Ø 60
Solid top usable surface (width):	380 mm
Solid top usable surface (depth):	700 mm
Oven working Temperature:	120 °C MIN; 280 °C MAX
Oven Cavity Dimensions (width):	575 mm
Oven Cavity Dimensions (height):	300 mm
Oven Cavity Dimensions (depth):	700 mm
Net weight:	130 kg
Shipping weight:	145 kg
Shipping height:	1030 mm
Shipping width:	900 mm
Shipping depth:	1020 mm
Shipping volume:	0.95 m ³
Certification group:	N9TG

If appliance is set up or next to or against temperature sensitive furniture or similar, a safety gap of approximately 150 mm should be maintained or some form of heat insulation fitted.